

CARBON CANISTER

A wide variety of activated carbon canisters for amine and glycol process purification. FSI uses all virgin carbon, not reclaimed, to ensure long service life and excellent solvent purification.



Our activated carbon is coal-based for maximum hardness to reduce dust. It has an optimum ratio of micropores to mesopores to remove dissolved organics, acidic degradation by-products and heat stable salt processors.

- A** High-strength cable steel bail handles won't pull out under heavy loads assuring trouble-free change outs.
- B** Extra-thick high-temperature gaskets are securely attached to the canister end caps.
- C** Two grain sizes of activated carbon allow you to choose the right media for your particular application requirements. The carbon bed is compacted for extended service life.
- D** The center tube is wrapped with jersey-knit woven cotton sock to prevent media migration. The top is sealed to prevent bypass through the carbon bed.

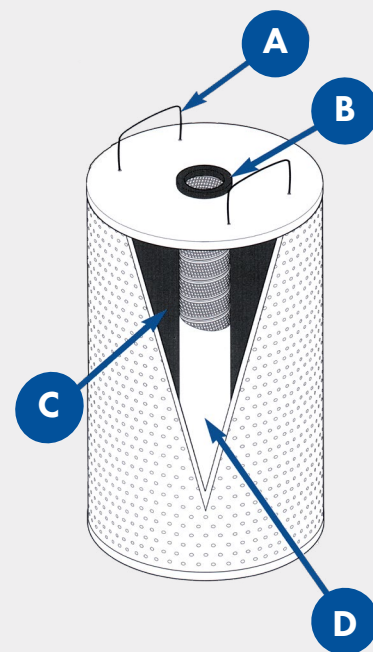

NOMENCLATURE CHART

(Example part number - other options available)

RF-11 22-AC-W-V

